

 FOLDING MACHINES

 COIL PROCESSING

 SHEARING SYSTEMS



H. WEISS MACHINERY & SUPPLY



SHEET METAL MACHINERY FOR LIFE

CIDAN
MACHINERY

THE CLEVER CHOICE - FOLDER



A CIDAN folding machine offers a convenient, flexible and efficient way to bend sheet metal into various details. Below you will find some of the advantages the folding machine offers in comparison with other process methods.

ERGONOMICS

When using a folding machine the sheet is supported by the back gauge table and back gauge stops during the bending process. This will provide a secure and safe working environment as the operator does not need to support the often heavy sheet during the bending process, which reduces the risk of work related injuries.

FAST SETUP

Our folding machines are equipped with an universal set of tools and a flexible software to provide operators with the tools they need to eliminate long tool set-ups, and be the most efficient with their operating time. The ProLink software provides the ability for remote offline programming and machine to profile interfacing.

NO MARKS OR SCRATCHES

The bending process on a folder will not leave any marks even on sensitive material such as pre-painted material and stainless steel.

QUICK TOOL CHANGES

With the Combi beam you will be able to change between straight and box tools in just a few seconds. The change is fully controlled by the machine's software and will take place without any hands involved – all you have to do is to press the foot pedal.

LOW TOOLING COST

The bending process on a folder eliminates wearing of the tooling, therefore the tools purchased with the machine should last the life of the machine.

EASY AND LOGICAL PROGRAMMING

By graphic programming during the process of drawing out your profile in the software, the machine will automatically calculate the parameters needed to successfully bend the part. Paired with our Automatic Folding Sequence parts are now programmed and produced more efficiently than before.



PROFITABLE PRODUCTION AND GOOD WORKING ENVIRONMENT

PRODUCT OVERVIEW



K15 p. 5



K25 p. 6



FORMA p. 7



PROLINO p. 8



PRO p. 9



PRO Z p. 10



MEGAPRO p. 11

Folding length m (")

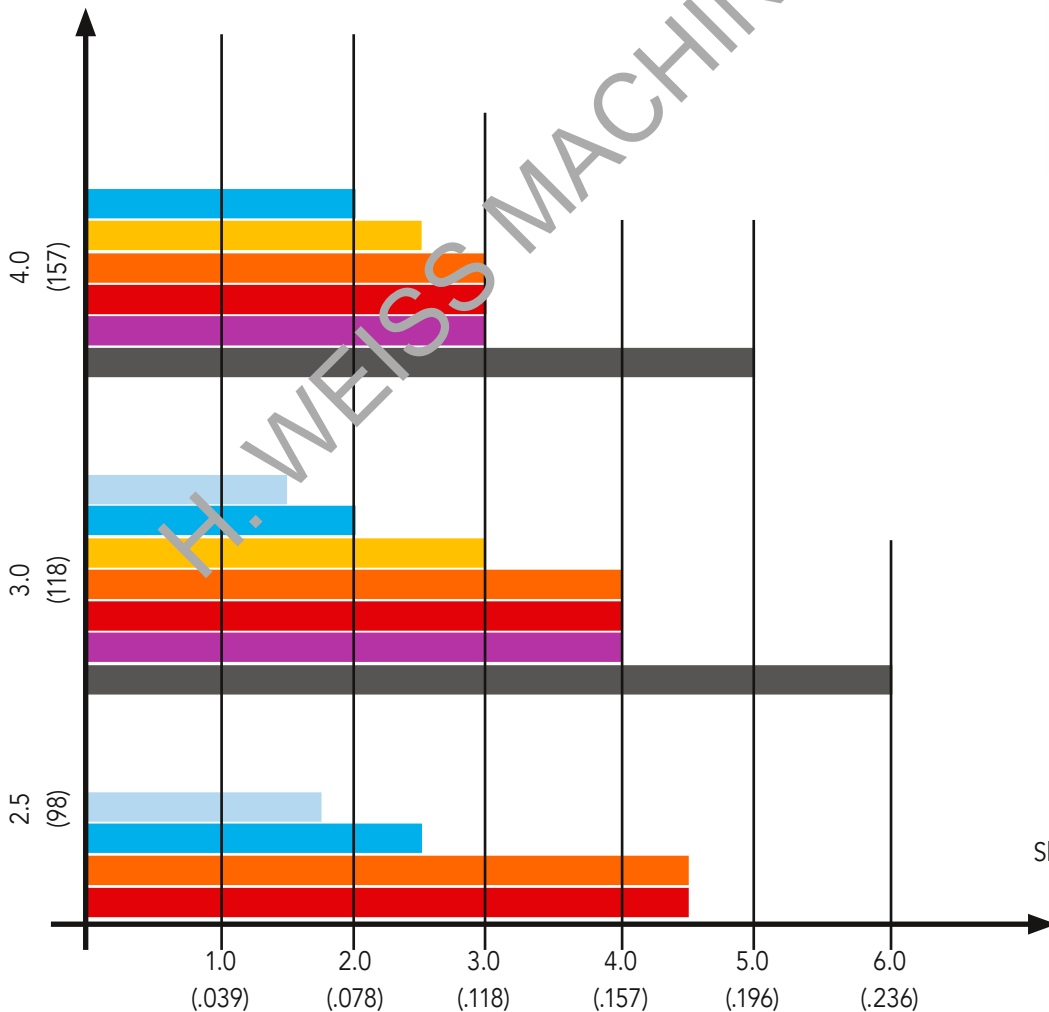

Sheet thickness* mm (")

* At tensile strength 400 N/mm²

OUR UNIQUE SOLUTIONS

COMBI BEAM TOOL CHANGER

The optional Combi beam is a flexibility machine like no other tooling system. With a simple rotation of the upper beam you can switch between the straight rail and divided box tooling in matter of seconds. This gives you the ability to form a larger variety of parts with little or no tool changing.

Advantages with Combi beam:

- Quick tool changes
- Large space around the tools
- Increased flexibility
- Same opening height regardless of tool selection



MULTIFOLD - MAXIMUM FLEXIBILITY

Divided tooling for maximum flexibility in every situation! With the optional Multifold execution the lower beam and folding beam tools are segmented. This caters to parts that have flanges facing downward into the machine. This allows the operator to bend weld tabs and parts with interrupted bend lines. Almost all of our models can be equipped with Multifold and an addition of height adjustable back gauge increases the benefit of Multifold, see below. Multifold requires high divided tools in the upper beam.

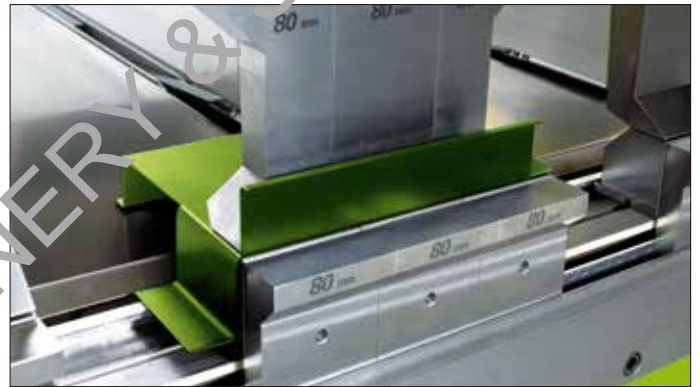

HEIGHT ADJUSTABLE BACK GAUGE

Our robust back gauge systems, AGS and SBG, can as an option be supplied with height adjustment. This is perfect for gauging reverse z-flanges on the back gauge.



Examples of folded parts



By using the CIDAN **K15** you have the ability to quick and easy create the part and profiles you need for your work. Just program the control system and then run. The compact folding beam moves quickly where you consistently stand near the machine without having to take a step back. First row gauging fingers in spring steel provides unbeatable small gauging measure and eliminate risks for marks in the material, which is common by machines that have cut-outs in the rail. Folding rails with quick change tooling system ensures fast changes and you get three widths to choose from as standard. When you buy a CIDAN K15, you get a folding machine that is easy to program, fast to run and, of course, gives a really good folding result. Job satisfaction, pure and simple.

- Crowning adjustment as standard always gives perfect folding result
- Two folding beam rails with width 7/10 mm (0.28"/0.39") and 20 mm (0.79") as standard
- Fast, reliable and user-friendly
- Choose between two control systems, EasyLink or ProLink X, both with plenty of features
- Multiple back gauge stops for both small and large parts across the bending length of the machine



Generous space around the tools for increased flexibility.

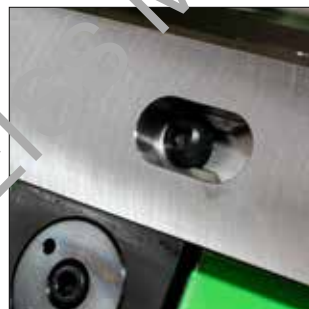

Quick change of tooling (bayonet style) and adjustable crowning.



Compact folding beam, only 280 mm (11"), grants easy and ergonomic work at the machine.

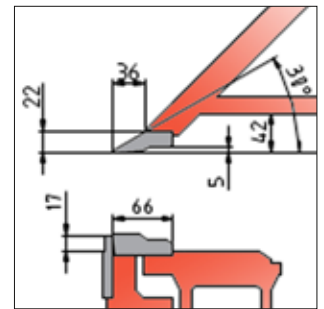

K15 with plenty of space behind the straight rail.

STANDARD RAILS

Straight rail 30°, double sided folding beam rail 7/10 mm (.275"/.394"), folding beam rail 20 mm (.787")

Model	Folding length	Folding capacity			Opening height	Outer dimensions****	Weight	Motor	
		Steel* mm (ga)	Stainless steel** mm (ga)	Aluminium*** mm (")				Clamping beam mm (")	Length x depth x height mm (")
K15-25	2550 (100)	1.75 (15)	1.10 (19)	2.60 (0.102)	115 (4.5)	3530 x 1595 x 1590 (139x63x63)	2000 (4.409)	0.75 (1)	1.1 (1.5)
K15-30	3100 (122)	1.50 (16)	0.90 (20)	2.20 (0.090)	115 (4.5)	4030 x 1595 x 1590 (159x63x63)	2370 (5.225)	0.75 (1)	1.1 (1.5)

Tensile strength *at 400 N/mm²-58000 lbf/in² (psi) – **at 600 N/mm²-87000 lbf/in² (psi) – ***at 200 N/mm²-29000 lbf/in² (psi) – ****With motorized back gauge EGS

K25



CIDAN **K25** is a universal and a strong folding machine. The cast iron side frame, twin drive of both folding beam and upper beam, and the eccentric clamping, give you a trouble-free operation at a low maintenance cost. The optional Combi beam provides the ability to change tools in seconds. The user-friendly control systems EasyLink or ProLink X allows easy programming and use regardless if the operator is experienced or not. Equip your K25 with ProLink X and you will get a much faster machine thanks to the more powerful motor and higher gearing. With the CIDAN K25, you will get a reliable and efficient work horse, day after day, year after year.

- Sturdy construction
- Built for demanding conditions, 100% duty cycle
- Same opening height regardless of tooling (Combi beam)
- Versatile and flexible
- Variety of options available for added flexibility
- Generous space around the tools for increased flexibility



Generous space around the tools for increased flexibility.



Quick change tooling (bayonet style) and adjustable crowning.



Compact folding beam grants easy and ergonomic work at the machine.

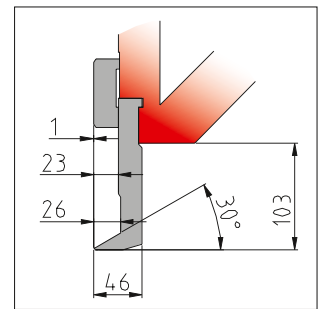

High divided tool 103 mm (4.0") together with combi beam.

STANDARD RAILS Straight rail 30°, double sided folding beam rail 7/10 mm (.275"/.394"), folding beam rail 20 mm (US version 25 mm/.984") **K25-40**, double sided folding beam rail 10/15 mm (.394"/.591"), folding beam rail 30 mm (1.18")

Model	Folding length	Folding capacity			Opening height	Outer dimensions****	Weight	Motor	
		mm (")	Steel* mm (ga)	Stainless steel** mm (ga)				Aluminium*** mm (")	Clamping beam mm (")
K25-25	2550 (100)	2.50 (13)	1.60 (16)	3.70 (0.146)	135 (5.3)	3680 x 1694 x 1800 (145x67x71)	3400 (7.495)	1.5 (2)	1.5 (2)*****
K25-30	3100 (122)	2.00 (14)	1.20 (18)	3.00 (0.125)	135 (5.3)	4190 x 1694 x 1800 (165x67x71)	3750 (8.267)	1.5 (2)	1.5 (2)*****
K25-40	4050 (159)	2.00 (14)	1.20 (18)	3.00 (0.125)	135 (5.3)	5180 x 1694 x 1800 (204x67x71)	4820 (10.626)	1.5 (2)	2.2 (3)

Tensile strength *at 400 N/mm²-58000 lbf/in² (psi) - **at 600 N/mm²-87000 lbf/in² (psi) - ***at 200 N/mm²-29000 lbf/in² (psi) - ****With Combi clamping beam and motorized back gauge AGS Base unit - ***** 2.2 kW (3) with ProLink X

FORMA



The CIDAN **FORMA** reflects decades of experience in both technology and design. FORMA from CIDAN is a "Cross-over" that handles both the requirements from small series production to single production. Speedy production (low cost), Sweet to the operator (easy ergonomics), Strong construction (machines for life). The simplicity in programming and quick tool changing reduces the setup time to a minimum. Dual drive of the upper beam together with a new locking principle, **CLS**, that holds the clamping beam, gives a high clamping pressure and a great folding result. Both rails and tools are easily changed where the crowning is easily adjusted. FORMA is equipped with Combi beam as standard and is also available in Multifold as an option.

- Sturdy construction
- Dual motors for the folding beam
- Same opening height regardless of tooling (Combi beam)
- Dual motors for the upper beam
- Variety of options available for added flexibility
- Generous space around the tools for increased flexibility



Automatic material sheet thickness adjustment, controlled by ProLink W

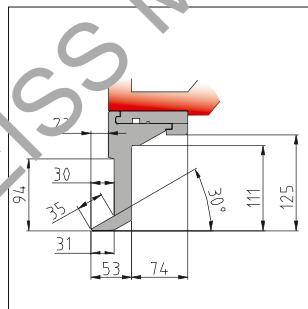

High divided tool 125 mm (4.9"), also available in 150 (5.9") and 200 mm (7.8") or C-shaped in 125 (4.9") or 150 mm (5.9").



Corner tools are included in high divided tools. Collapsible corner tools are available as options.

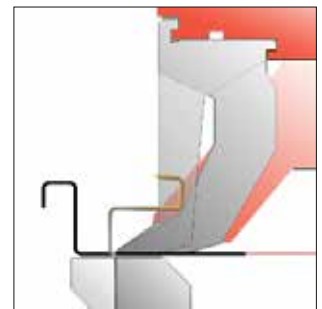

With C-shaped tools you can fold deeper profiles than with standard tools or straight rail.

STANDARD RAILS

Straight rail 30°, folding beam rail 15 mm (.591"), folding beam rail 30 mm (1.18")

Model	Folding length	Folding capacity			Opening height	Outer dimensions****	Weight	Motor	
		Steel* mm (ga)	Stainless steel** mm (ga)	Aluminium*** mm (")				Clamping beam kW (hp)	Folding beam kW (hp)
FORMA 30	3100 (122)	3.00 (11)	1.90 (14)	4.50 (0.177)	195 (7.7)	4465 x 2370 x 1980 (176x93x78)	5000 (11.023)	2 x 1.1(2 x 1.5)	2 x 1.5 (2 x 2)
FORMA 40	4100 (161)	2.50 (12)	1.60 (16)	3.70 (0.146)	195 (7.7)	5465 x 2370 x 1980 (215x93x78)	5800 (12.786)	2 x 1.1(2 x 1.5)	2 x 1.5 (2 x 2)

Tensile strength *at 400 N/mm²-58000 lbf/in² (psi) - **at 600 N/mm²-87000 lbf/in² (psi) - ***at 200 N/mm²-29000 lbf/in² (psi) - ****With motorized back gauge AGS Base unit

PROLINO

CIDAN combines over 20 years of production experience of heavy gauging machines with the **PROLINO**, a production that started with the well-known K50, earning the reputation to deliver a reliable and proven 4 mm (9 ga) x 3.1 meters (122") machine to the heavier sheet metal industry. The advantages of PROLINO is the ability to customize your CIDAN folder to the exact specifications needed for your application. This machine can fold complex profiles and large panels with high precision, increased flexibility and productivity, therefore it is the perfect choice for industrial manufacturing or a job shop.

- The combination of an eccentric pull down that drives the upper beam with 50 tons (55US) clamping pressure and dual drive for the folding beam makes the machine perfect for industrial manufacturing.
- With the crowning system it is possible to make exact bends with high precision and a precise folding radius.
- Optional Combi beam with high divided tooling and straight rail.
- The PROLINO can be prepared for high divided tools from 152 mm (5.9") up to 254 mm (10") height. Change of tool height does not require any machine change.

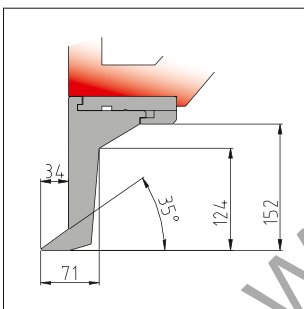

High divided tool 152 mm (5.9"), also available in 254 mm (10") or C-shaped in 152 mm (5,9").



AGS back gauge table for PROLINO Standard and PROLINO Combi beam machines.

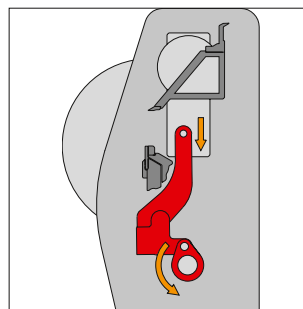

Eccentric drive gives optimal opening and closing speed, combined with high clamping pressure.

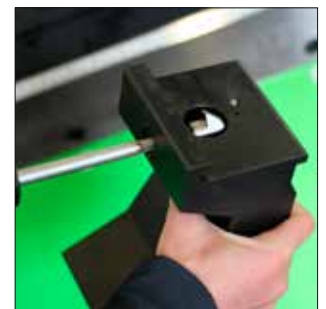

Divided tools with quick change for combi beam.

STANDARD RAILS

Straight rail 35°, folding beam rail 15 mm (.591"), folding beam rail 35 mm (1.38")

Model	Folding length	Folding capacity			Opening height	Outer dimensions****	Weight	Motor	
		Steel* mm (ga)	Stainless steel** mm (ga)	Aluminium *** mm (")				Clamping beam kW (hp)	Folding beam kW (hp)
PROLINO 30	3100 (122)	4.00 (9)	2.50 (12)	6.00 (0.236)	200 (7.88)	4400 x 2535 x 2100 (173x100x83)	7800 (17.160)	4.0 (5.5)	5.5 (7.5)
PROLINO 40	4100 (161)	3.00 (11)	1.90 (14)	4.50 (0.177)	200 (7.88)	5400 x 2535 x 2100 (213x100x83)	9670 (21.274)	4.0 (5.5)	5.5 (7.5)

Tensile strength *at 400 N/mm²-58000 lbf/in² (psi) - **at 600 N/mm²-87000 lbf/in² (psi) - ***at 200 N/mm²-29000 lbf/in² (psi) - ****With Combi clamping beam and motorized back gauge AGS Base unit



The **PRO** is CIDANs most multilateral machine with many features as standard. The integrated back gauge, has the possibility to produce complex parts from the folding side. Heavier material and larger parts can be handled from the gauging side of the machine to improve work ergonomics and increase the quality. It is possible to replace two operators with one and still be able to produce parts up to four times faster and with better accuracy compared to a press brake.

- Dual drive of clamping beam gives incredible speed and accuracy. The servo drive also increases hemming capacity to 50 tons (55US)
- Combi beam and Multifold with high divided tools and straight rail in combination with segmented tools in the lower beam and folding beam can facilitate extremely complicated folding work.
- Automatic folding beam crowning and automatic sheet thickness adjustment for precise folding.
- With high speed and extreme accuracy of the back gauge, exact measuring is ensured and with servo driven folding beam you will get the right folding angle every time.
- Height adjustable back gauge table available.

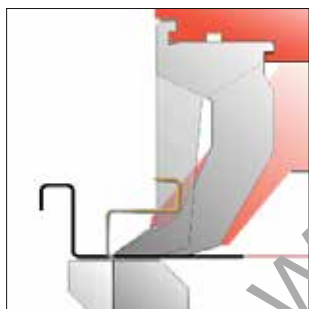

With C-shaped tools you can fold deeper profiles than with standard tools or straight rail.



Laser scanner on the folding side, recommended when working from gauging side.



SBG height adjustable back gauge table for PRO.



Both AGS and SBG back gauge tables are available in L-, J- or U-shape.

STANDARD RAILS

Straight rail 35°, divided folding beam rail 15 mm (.591"), divided folding beam rail 35 mm (1.38")

Model	Folding length	Folding capacity			Opening height	Outer dimensions****	Weight	Motor	
		Steel* mm (ga)	Stainless steel** mm (ga)	Aluminium*** mm (")				Clamping beam mm (")	Clamping beam kW (hp)
PRO 30	3100 (122)	4.00 (9)	2.50 (12)	6.00 (0.236)	200 (7.88)	4400 x 2535 x 2100 (173x100x83)	8130 (17.886)	4.0 (5.5)	5.5 (7.5)
PRO 40	4100 (161)	3.00 (11)	1.90 (14)	4.50 (0.177)	200 (7.88)	5400 x 2535 x 2100 (213x100x83)	10500 (23.100)	4.0 (5.5)	5.5 (7.5)

Tensile strength *at 400 N/mm²-58000 lbf/in² (psi) - **at 600 N/mm²-87000 lbf/in² (psi) - ***at 200 N/mm²-29000 lbf/in² (psi) - ****With motorized back gauge SBG-15

PRO Z



CIDAN's **PRO Z** is our new robust and highly rated up- and down folding machine, mainly targeted for industrial applications. The PRO Z model folds both upward and downwards to eliminate the need for an operator to flip the material. This provides excellent opportunities for time-efficient folding of complex details with one operator. Divided tools in both folding- and upper beam provides maximum flexibility with automatic tool locking. The machine's powerful motors contributes to a strong machine that works at high speed and precision.

- Folds upwards and downwards, no need to flip the material
- 150 mm movement of folding beam, to move outside of material on folding side.
- Tooling in two different shapes and three different heights, one shape suitable for folding side operation
- Standard with Combi upper beam and Multifold CNC controlled sheet thickness and folding center adjustment.
- The folding beam can be used as front gauge up to 150 mm.
- The PRO Z can be equipped with our Optimal Eccentric Drive **OED**^{PAT PENDING} for maximum clamping power regardless of tool height and sheet thickness.



Smart storage of tools for easy access.



Folding beam in lower position before clamping.



Folding beam in upper position before clamping.



Front vacuum fingers available for PRO Z.

RAILS

A variety of rails and tools are available, discuss the best set up with your sales representative.

Model	Folding length	Folding capacity			Opening height***	Outer dimensions****	Weight	Motor	
		Steel* mm (ga)	Stainless steel** mm (ga)	Aluminium*** mm (")				Clamping beam mm (")	Length x depth x height mm (")
PRO Z 30	3200 (126)	4.0 (9)	2.50 (12)	6.00 (0.236)	254 (10)	4700 x 3590 x 2250 (185x141x89)	11850 (26.124)	2 x 3.8 (2 x 5.1)	2 x 9.5 (2 x 12.9)
PRO Z 40	4100 (161)	3.0 (11)	1.90 (14)	4.50 (0.177)	254 (10)	5700 x 3590 x 2250 (224x141x89)	13980 (30.820)	2 x 3.8 (2 x 5.1)	2 x 9.5 (2 x 12.9)

Tensile strength *at 400 N/mm²-58000 lbf/in² (psi) - **at 600 N/mm²-87000 lbf/in² (psi) - ***at 200 N/mm²-29000 lbf/in² (psi) - ****equipped with OED, for all tool heights - *****With motorized back gauge AGS Base unit

MEGAPRO



CIDAN folding machine model **MEGAPRO** is built in a strong and solid construction, which is important in order to fold perfect details in 6 mm (1/4") steel or 4 mm (9ga.) stainless steel (applies on 3100 mm (122") folding length). The strong beams withstand the powerful folding forces by means of a very strong construction. CIDAN model MEGAPRO has many advanced CNC functions like adjustment of sheet thickness, folding center and crowning. MEGAPRO also has an automatic tool locking system in the upper beam as a standard feature.

- Dual servo driven motors for both clamping and folding beams gives incredibly fast speed and accuracy. High clamping pressure for accurate forming.
- CNC adjustment of folding center, sheet thickness and crowning.
- The clamping beam opens as the folding beam returns so that they are positioned for the next step simultaneously.

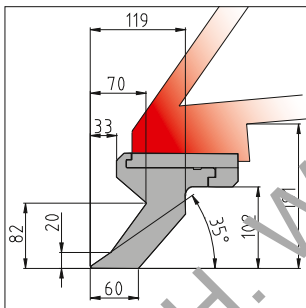

High divided tool, 102 mm (4.01") also available in 152 mm (5.9").



Here a J-shaped back gauge, allowing one operator to handle large details. Height adjustment as option.



Power enough to fold up to 6 mm (0.236") mild steel.



CNC adjustment of folding center, sheet thickness and crowning.

STANDARD RAILS

Divided straight rail 35°, divided folding beam rail 20 mm (.787"), divided folding beam rail 60 mm (2.36")

Model	Folding length	Folding capacity			Opening height	Outer dimensions****	Weight	Motor	
		Steel* mm (")	Stainless steel** mm (")	Aluminium*** mm (")				Clamping beam mm (")	Length x depth x height mm (")
MEGAPRO 30	3100 (122)	6.0 (0.236)	3.80 (.149)	9.00 (0.354)	350 (13)	4700 x 3590 x 2250 (185x141x89)	11850 (26.124)	2 x 5.5 (2 x 7.5)	2 x 4.0 (2 x 5.5)
MEGAPRO 40	4100 (161)	5.0 (.196)	3.20 (.126)	7.50 (0.295)	350 (13)	5700 x 3590 x 2250 (224x141x89)	13980 (30.820)	2 x 5.5 (2 x 7.5)	2 x 4.0 (2 x 5.5)

Tensile strength *at 400 N/mm²-58000 lbf/in² (psi) - **at 600 N/mm²-87000 lbf/in² (psi) - ***at 200 N/mm²-29000 lbf/in² (psi) - ****With motorized back gauge SBG-15

AGS ACCURATE GAUGING SYSTEM



AGS^{PATENTED}

By processing and gathering information about our customer needs we designed our most flexible and innovative back gauge system so far. With the AGS back gauge you can design your back gauge exactly to your needs. The base unit spans over the length of the machine and has a depth of 1550/1050/1550 mm (61/41.3/61"). Then you can install additional modules to the right or left up to a total depth of 4300 mm (149") and add in the middle section as well. You choose if you want your back gauge straight or shaped as a J, L or U. Should your needs change, you can with reasonable effort expand your back gauge by adding modules afterwards. It is even possible to add height adjustment afterwards. AGS back gauge is equipped with ball screw, linear guides and servo motor for highest precision and repeatability. The back gauge speed enables the productivity to increase and at the same time, decreases the costs of your forming operation. Front stop units are made of spring steel as standard, solid front stop units are optional. The stop units can be dropped down automatically in every program row, which prevents any collision with the stop units when the sheet needs to be rotated. AGS with height adjustment is available for FORMA and PRO Z.



The back gauge system is driven by a servo motor with ball screw and linear guides which guarantees high precision and accuracy. Each back gauge position can be reached within 2 seconds.



Gauging rails can easily be moved sideways to pre-drilled holes for maximum adaptation, (not for AGS FH FR). The back gauge pans with ball transfers always fit due to the clever back gauge pan system.

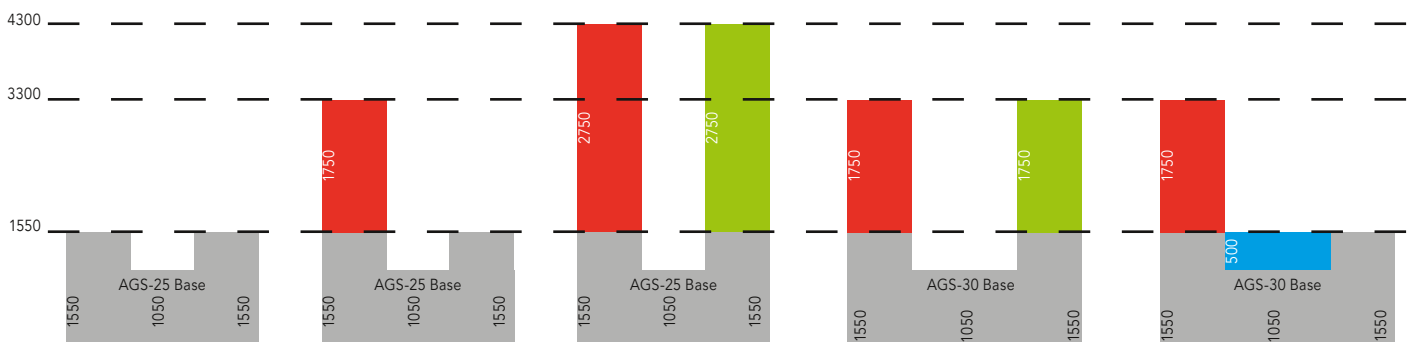

Examples of different back gauge configurations

AGS ACCURATE GAUGING SYSTEM

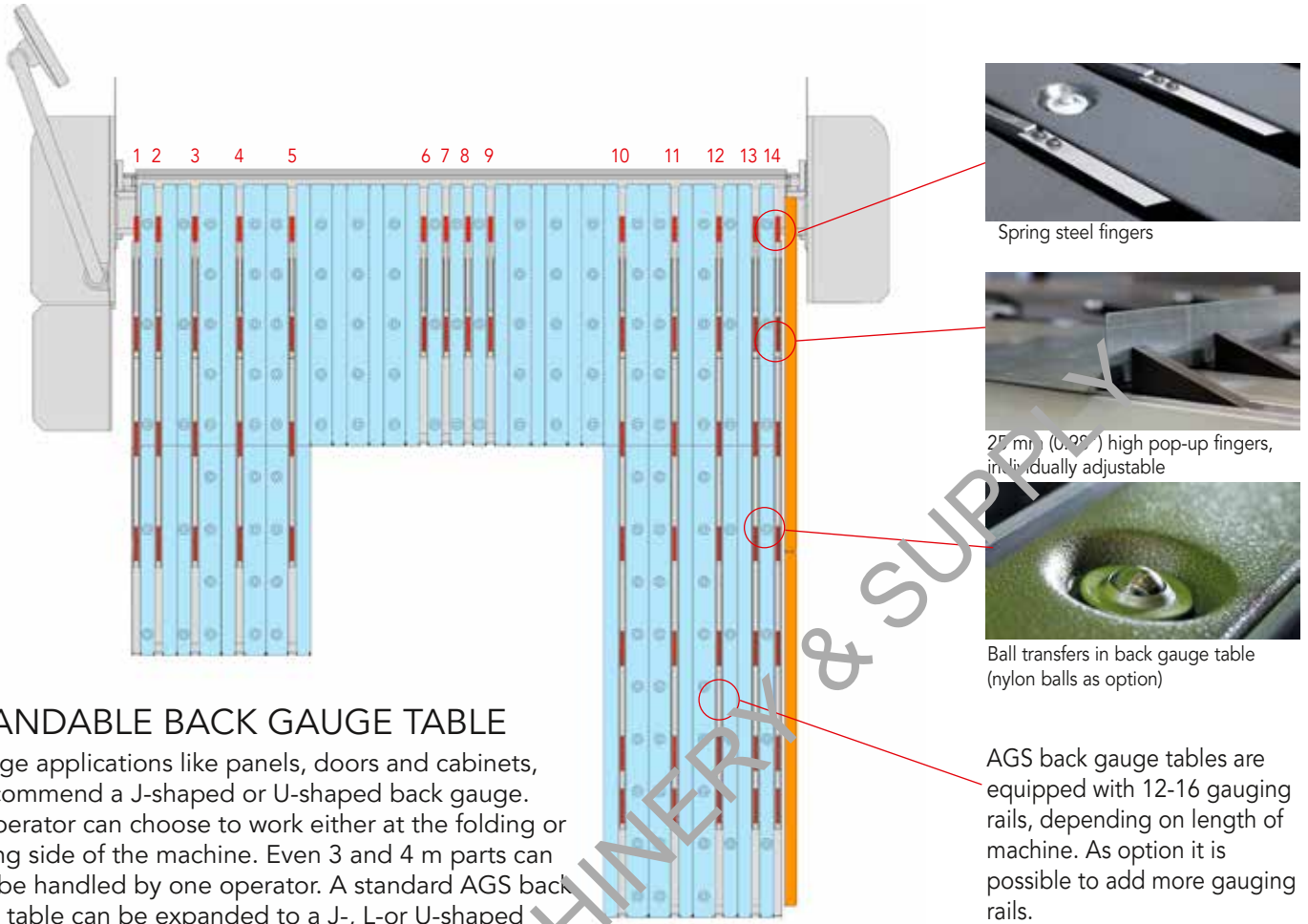

EXPANDABLE BACK GAUGE TABLE

For large applications like panels, doors and cabinets, we recommend a J-shaped or U-shaped back gauge. The operator can choose to work either at the folding or gauging side of the machine. Even 3 and 4 m parts can easily be handled by one operator. A standard AGS back gauge table can be expanded to a J-, L- or U-shaped back gauge table afterwards. See below for examples of different configurations.

AGS back gauge tables are equipped with 12-16 gauging rails, depending on length of machine. As option it is possible to add more gauging rails.



Back gauge panels can be moved backwards when folded details requires free space behind the lower beam tool.



Our back gauge system can be supplied with height adjustment. This is perfect for gauging reverse z-flanges on the back gauge. Height adjustable back gauge requires multifold execution (not for FORMA), and is controlled by ProLink.

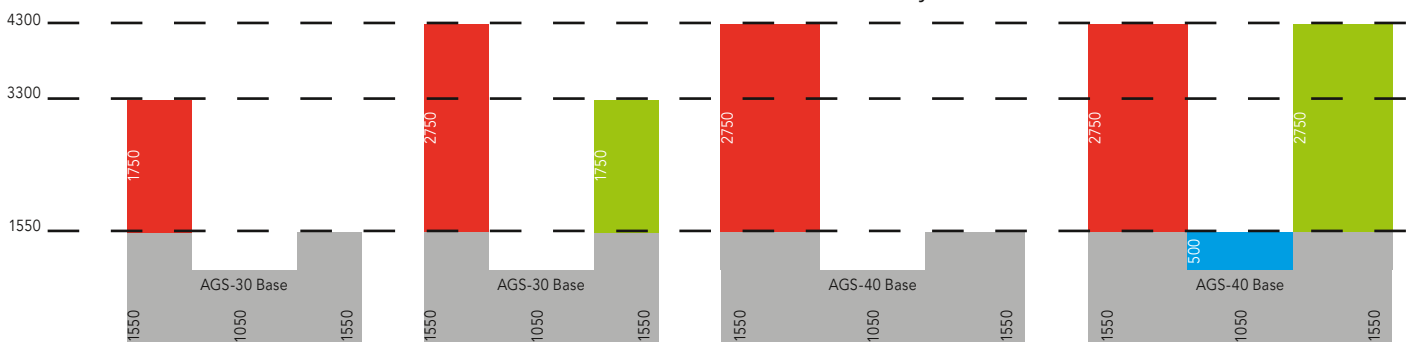

Examples of different back gauge configurations

EGS ENTRY GAUGING SYSTEM



Spring steel fingers

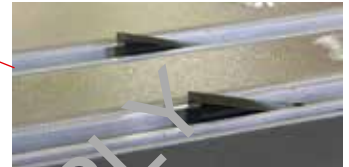

Pop up finger

EGS

The new EGS back gauge is a cost effective back gauge without the customization capabilities of the AGS system. Designed specifically for the K15 and K25, the EGS-25 is equipped with 10x2 stop units, EGS-30 with 12x2 stops units and EGS-40 has 14x2 stop units. First row stop units are made of spring steel as standard. The back gauge has one servo motor and belt drives on both sides and it takes less than two seconds to get an exact position between 2 and 1020 mm (.080"–40.2"). All the stop units can drop down automatically to avoid collision when the material needs to be rotated on the table. Available for all models of K15 and K25 only (ball transfer is available as option).

CONTROL SYSTEM



EASYLINK

EasyLink is a complete and user-friendly control system, fast and easy to program. **EasyLink** has the possibility to store 1000 profiles each with 99 steps. In every program step, the angle, gauge dimension, opening height, clamping pressure and hem pressure can be programmed.

Some of the other possibilities available with **EasyLink** are copying programs, incremental dimensioning, and radius folding. From the touch screen the operator gets clear messages about the programming and operation. The Combi beam can be fully integrated into this control. The touch screen panel is mounted on a rotating bracket, so that the operator easily can adjust the screen to the situation.



CONTROL SYSTEM

PROLINK

This latest version of ProLink takes programming to the next level keeping the user friendliness the same while adding a variety of new functions. This includes *Batch function*, which allows you to split the folding sequences into groups to save tool changing time. *Time estimation* is also a new feature where the control system calculates the time to produce one profile or a complete batch of profiles. Another feature is *Import of dxf files*; import your drawings directly into ProLink via USB. A new feature is the possibility to plug in a USB *Barcode reader*. By attaching barcodes to your sheets and scan, the control systems knows how to fold the sheet. We have also included *Remote access via TeamViewer*, possible problems can be investigated and solved remotely, quickly and easily. *Automatic Folding Sequence (AFS)*, with collision detection and calculation of an optimal folding sequence. The **ProLink** can produce perfect parts efficiently and safely, even for an unskilled operator.



The control system with its simple functions is very easy to understand and learn. Its interactive graphic pictures are shown to the operator with instructions like rotate or flip the part, a condition to correctly being able to produce complicated details. In the control memory you can store a large amount of programs and you can also store programs on a USB stick as well. Every program can be saved with a graphical icon, with name and information.

The **ProLink** calculates cut size and automatically creates a program. The finished part is shown with its actual folding sequence. The touch screen is mounted on a pendant arm that can be rotated for optimal viewing. It is also possible to turn the screen to the gauging side of the machine when folding large details. With the offline-software option, programming can be completed in the office away from the machine.

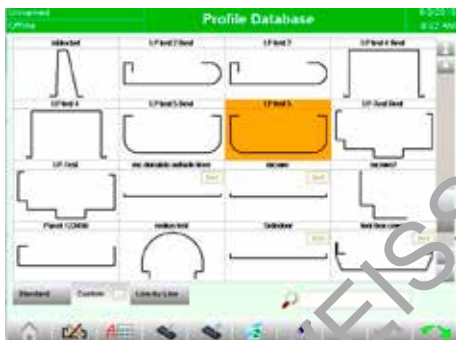

Find a detail similar to what you need in the library and use the drawing to create your own new detail.



A second option is using the drawing program and create your own profile.



A third programming alternative is Line By Line. Set angles and dimensions and the machine will be ready to fold.



This function automatically calculates the folding sequence, detects collisions and visualises this to the operator.

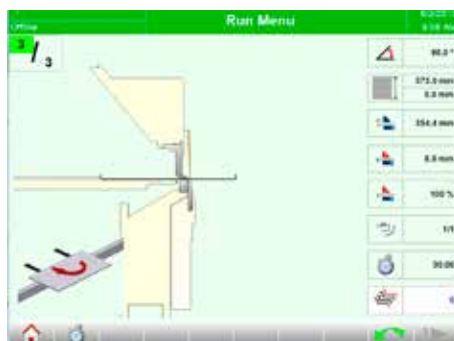

Shows the folding sequence and how to handle the material.

OPTIONS



SQUARING ARM (not for EGS)

Makes positioning of large and narrow parts easier. Available in two lengths, 1500 mm (59") and 3000 mm (118") for left and/or right hand side.



ROUND STRAIGHT RAILS

We offer a numerous different straight rails with radius from 0.75 mm (.029") up to 10 mm (.394"). Recommended for radius bends up to R10 in higher volumes.



MOVEABLE FOOT PEDAL ON RAIL

Allows the operator to move the foot pedal quickly and smoothly along the folding area. Appropriate when folding is done with several tooling stations. Also, the foot pedal rail is considered a great added safety feature when bolted to the floor. When the operator engages the foot pedal, the operator is away from the swinging folding beam.



TOOL CART

Safely store the divided tooling for your CIDAN folder. The tool cart is recommended to decrease the risk of damaging tools and misplacing tools during tool changing. It is possible to store divided rails on the cart and there is room for hand tools for the operators and machine instruction manual. The cart is equipped with lockable wheels and pull handles. Especially recommended if the machine is equipped with the Multifold tooling system.



LASER SAFETY SCANNER

The safety scanner provides extra safety with two modes when operating machine from folding side or gauging side.

The scanner prevent any person to enter the working area where a collision with the folding beam is possible.

EQUIPMENT

	K15	K25	FORMA	PROLINO	PRO	PRO Z	MEGAPRO
Control system							
EasyLink	●	●					
ProLink	○	○	●	●	●	●	●
Tooling							
Standard beam with straight rail	●	●		●			
Combi beam tool changer		○	●	○	●	●	
Multifold			○		●	●	●
Crowning							
Adjustable crowning	●	●	●				
Automatic crowning					●		●
Safety features							
Safety bumper on folding beam			○		○		○
Laser scanner	○	○	○		○	○	
Back gauge tables							
EGS	○	○					
AGS	○	○	○	○		○	
SBG					○		○
CNC height adjustment			○		●	○	○
Solid fingers	○ ²	○ ²	○	○	○	○	○
Squaring arms	○ ²	○ ²	○	○	○	○	○
Front vacuum fingers, version VA						○	
Others							
Adjustable folding beam speed		●/○ ¹	●	●	●	●	●
CNC adjustment of sheet thickness			●		●	●	●
Central lubrication		○	○		○	○	●
Optimal eccentric drive OED ^{PAT PEND.}						○	
CNC adjustment of folding center						●	●

● standard, ○ option, ¹depending on length of machine - ²only for AGS

CIDAN AND FORSTNER COIL LINE ADVANTAGES

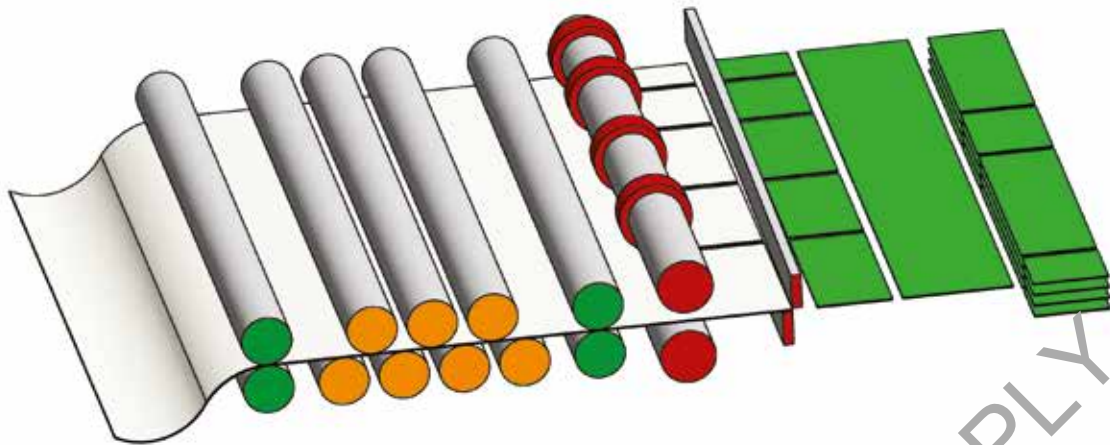

REDUCTION OF MATERIAL COST

Cost of material in coil is 15–20% less than cost of material in blanks

REDUCTION OF SCRAP MATERIAL

Instead of fixed sized blanks, you can produce any size needed without scrap

REDUCTION OF PROCESSING TIME

From coil to required blanks with minimum material handling

REDUCTION OF MAN POWER

One operator can load coil and operate a whole line
No lifting and handling of heavy sheets

JUST IN TIME

Quick response to customer demand through flexible sheet sizes

SPECIAL SOLUTIONS

Punching unit and integration in lines

COMPACT SIZE OF FULL LINE



COMPACT



The CIDAN cut to length line model **COMPACT** is a fully automatic line and is supplied in a very compact construction for coil width 1250 mm (49"). No other manufacturer can beat the quality and accuracy of the cut and slit pieces in a line of this size. With this line, the productivity can be drastically increased by programming different lengths and pieces optimizing the use of material and minimizing scrap.

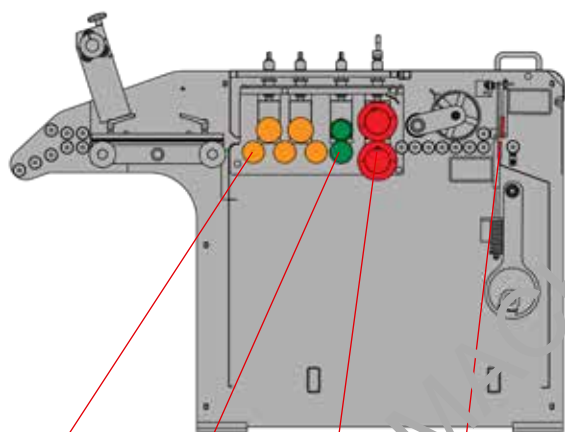

Straightening rolls Feeding rolls Slitting unit Mechanical shear

The **COMPACT** has a straightening unit with 5 rolls and the cut to length is done by a motorized mechanical shear.

The LineLink control system with a color touch screen gives you the possibility to store many programs as well as a library of coils. LineLink is available in many different languages.

The **COMPACT** is prepared for, and can be fitted with a slitting unit and multiple slitting knives.

The **COMPACT** will handle pre-painted sheets and other sensitive materials.

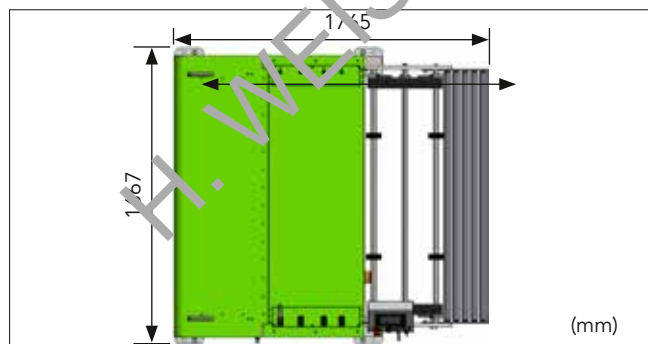

The COMPACT offers infeed, straightening, slitting and shearing in a compact size.



Digital indicators ensures precise adjustments time after time.

STANDARD

5 straightening rolls, 2 infeed rolls, chain drive

Model	Cutting width	Capacity			Speed	Outer dimensions	Motor	Weight
	mm (")	Steel* mm (ga)	Stainless steel** mm (ga)	Aluminium*** mm (ga)	m/min ft/min	Length x Width x Height mm (")	kW (hp) shear + feeding	kg (lbs) Approx.
COMPACT 12	1250 (49)	1.25 (18)	0.75 (24)	1.75 (15)	15 (49)	1765 x 1667 x 1481 (69x65x58)	1.5 (2.0) + 1.1 (1.5)	1500 (3307)

Tensile strength *at 400 N/mm² - 58000 psi - **at 600 N/mm² - 87000 psi - ***at 200 N/mm² - 29000 psi

SLITTING



SLITTING UNIT

All our lines can be fitted with a slitting unit that consists of upper and lower rolling knives. The unit can be equipped with 1–8 pair of divided slitting knives. The slitting unit can be activated or deactivated by moving the upper knives up or down via a handle.

The divided slitting knives unlock easily with an Allen Key.



The knives on our slitting unit are easily adjusted and they all have two cutting edges to double the lifespan. The knives are made of high quality steel and they are precision grinded and hardened, which guarantees accurate slitting.

Divided slitting knives, apart and assembled

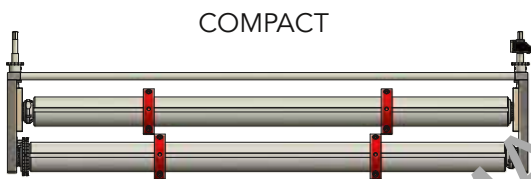

MINIMUM SLITTING WIDTH ON CTL-LINE

The minimum slitting width on **COMPACT** machines is 30 mm by single slittings and 60 mm by multiple slittings, due to the shape and size of the slitting knives.

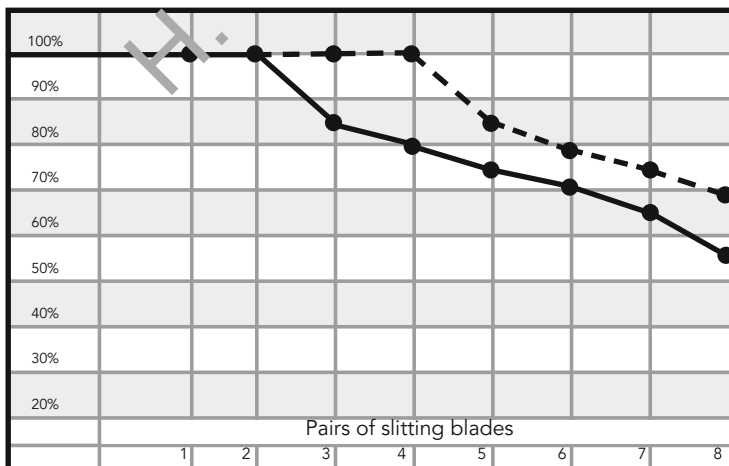

SLITTING CAPACITY

The diagram describes the maximum slitting capacity with different number of slitting knives. The value 100% refers to the maximum capacity of each cut to length machine. Lines describing maximum sheet metal thickness in the use of different number of slitting knives. Use the "dashed line" for capacity when trim cutting is done.

LINELINK TOUCH SCREEN CONTROL

Our COMPACT coil processing unit is equipped with the LineLink Control, a 6" color touch screen that is very user friendly. The LineLink has a memory card where all parameters, programs and coils are stored.

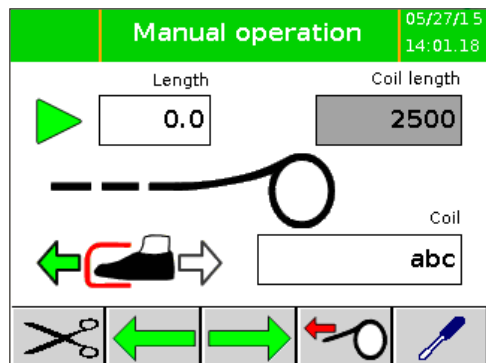

THE MANUAL OPERATION MODE IS USED FOR:

- Manual feeding of material in both directions
- Manual clean cut
- Select coil from library
- Set length for single cut
- Choose language, metric/imperial and other regional settings

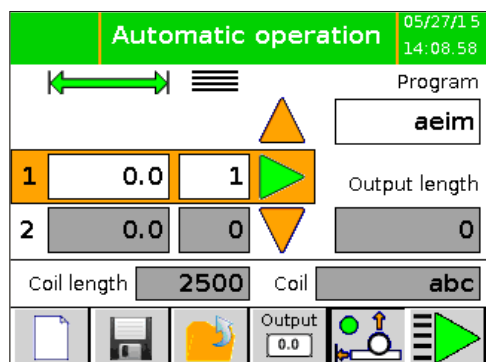

THE AUTOMATIC OPERATION MODE IS USED FOR:

- Writing a program by selection of cutting length and quantity
- Each program can have several lengths and quantities in combination
- Single or automatic mode
- Storing of programs in a large memory bank
- Reverse function for cutting aluminium

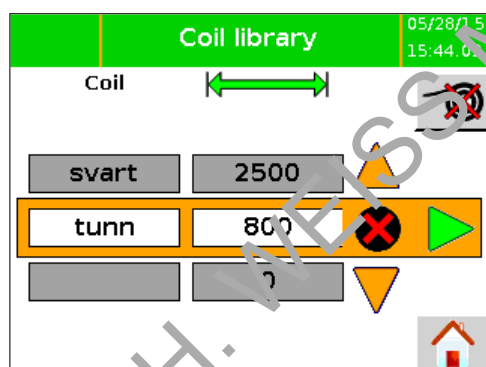

COIL LIBRARY

- Storing of different coils. Enter coil width, weight, length, color, quality, thickness etc. per coil.
- By entering the length of material in a coil, the automatic calculation processor will advise whether a coil has sufficient material for a certain program.

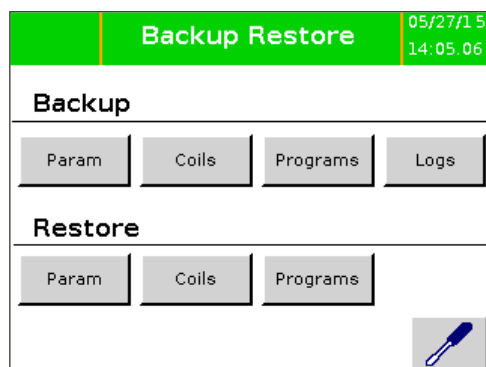

BACKUP RESTORE

- This screen mode is used to back up programs, parameters and coil library on a memory stick

OPTIONS



DEVICE FOR ADDING PROTECTIVE FOIL

Device for adding protective foil on top side and / or lower side of the material (order separately). This feature is equipped with a brake, in order to adjust the tension and is recommended for sensitive material.



PUNCHING UNIT

Instead of a slitting unit we have the possibility to integrate a punching unit in two different versions.

Punching unit for notching corners or other angles:

Infeed from coil, straightening sheet with 5 rolls, positioning and punching with a square or triangle tool, cut to length in one cycle.

Punching unit for isolation tubes:

Infeed from coil, straightening sheet with 5 rolls, positioning and punching holes for blind rivets, cut to length and 9 mm pre-bending in one cycle.

Contact us for specifications.



SLITTING UNIT

Change position of the slitting knives

Our slitting knives are easily adjusted. A feature in the LineLink control system, makes it easy to enter the clamping bolts for the slitting knives.

Shearing table with rolls (standard)

Friction free shearing table with rolls to prevent scratches in sensitive materials like aluminum, zinc, copper etc..

MANUAL DECOILERS 1-5 TONS CAPACITY

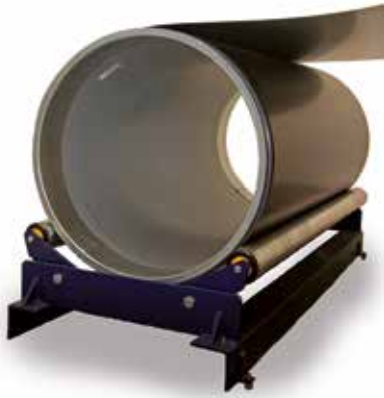

CRADLE

- 4 supporting rolls and 2 side rolls
- Fixture for transportation by pallet jack



DO 2-12

- Manual decoiler with single frame and expandable mandrel
- Brake system, manually adjustable
- Fast coil changing
- Recommended for sensitive materials



DC 5

- Manual decoiler with expandable mandrel
- Brake system, manually adjusted
- Recommended for sensitive materials

Model	Max coil weight	Coil width	Capacity max	Coil diameter	
	kg (lbs)			mm (")	mm (ga)
Cradle	1000 (2200)	1250 (49)	1.0 (20)		
DO 2-12	2000 (4400)	1250 (49)	1.5 (16)	360-520 (14-25)	850 (33)
DC 5-12	5000 (11000)	1270 (50)	1.5 (16)	360-630 (14-25)	1100 (43)
DC 5-15	5000 (11000)	1520 (60)	1.5 (16)	360-630 (14-25)	1100 (43)

ROTOCOIL



Four support plates to maintain a perfect round shape



ROTOCOIL is a heavy duty motorized decoiler for up to 5 and 10 tons coils developed for high speed production. The **ROTOCOIL** communicates with the CIDAN cut to length / slitting line, to ensure a smooth and fast production. The motor is frequency controlled and the decoiler can reach a maximum speed of 45 meters per minute.

The CIDAN model **ROTOCOIL** decoiler is a unique innovation with an intelligent and clean design, where components are placed inside the machine construction, in order to prevent any damages in heavy industrial environments.

The hydraulic mandrel has four support plates to maintain a perfect round coil shape during expansion. The mandrel is equipped with hydraulic wedges to keep the coil tight to the mandrel during the whole decoiling process.

The ultrasonic loop control sensor measures the distance from floor to the loop and makes sure the decoiler will start and stop decoiling smoothly.



WIRELESS REMOTE CONTROL

The wireless remote control is a unique solution to avoid cables and gives flexibility especially when changing coils.



PRESSURE ARM

When working with heavy material, the pneumatic pressure arm is essential in making sure the coil stays closed. It also simplifies the changing and handling of the coils.

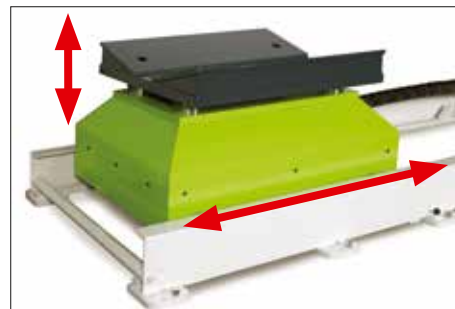

COIL WAGON (OPTION)

The hydraulic coil wagon makes the changing and handling of coils safe, easy and quick. The wagon is an important feature since it will eliminate coil damage during fork lift or overhead crane loading and unloading.

STANDARD

4 hydraulic expansion plates, pneumatic pressure arm, wireless remote

Model	Coil weight	Max coil width	Capacity max	Speed	Outer dimensions*	Motor	Coil diameter	
	kg (lbs)	mm (")	mm (ga)	m/min (ft/min)	Length x Width x Height mm (")	kW (hp)	Inside mm (")	Outside mm (") max
ROTOCOIL 5-15	5000 (11000)	1550 (61)	2.5 (12)	45 (150)	4618 x 1404 x 1882 (182x55x74)	3.0 (4)	436 - 546 (17,2 - 21,4)	1300 (51)
ROTOCOIL 10-15	10000 (22000)	1550 (61)	2.5 (12)	45 (150)	4839 x 1407 x 1952 (191x55x77)	7.5 (10)	475 - 585 (18,7 - 23,0)	1500 (59)

*Included coil wagon CW 5 or CW 10 and pressure arm

COIL PROCESSING OVERVIEW

	COMPACT	ROTOCOIL
Control system LineLink with touch screen	●	
Feeding		
Sheet guide for in-feed	●	
2 feeding rolls (1 rubber coated)	●	
Straightening		
5 straightening rolls	●	
Two rubber coated upper straightening rolls	○	
Slitting		
Slitting unit with 1-8 pairs of divided slitting knives	○	
Shear		
Guillotine shear with hold down beam	●	
Double edged blades	●	
Other		
Device for adding protective foil	○	
Punching unit	○	
Forced cooling for cutting motor	○	
Scrap rewinder	○	
Electric cabinet on the right side (left side is standard)	○	
ROTOCOIL		
Ultrasonic loop control and wireless remote control		●
Coil wagon		○
ROTOCOIL as a stand alone unit for CTL lines without LineLink control		○
Mandrel adapter plates for increased inside diameter of coils		○

● standard, ○ option

SHEARS - RAPIDO



The CIDAN model **RAPIDO** is a heavily built mechanical guillotine shear. The **RAPIDO** can cut material with thicknesses from minimum to maximum without any settings at all. This shear proves our philosophy regarding the environment as it uses minimum energy and has a very low noise level.

The shear is well equipped as standard and also has a wide range of options such as different back gauges and sheet handling systems.

- User friendly – After 10-15 minutes of training you are able to use all the features on the Rapido.
- High Speed – One perfect cut in less than 2 seconds.

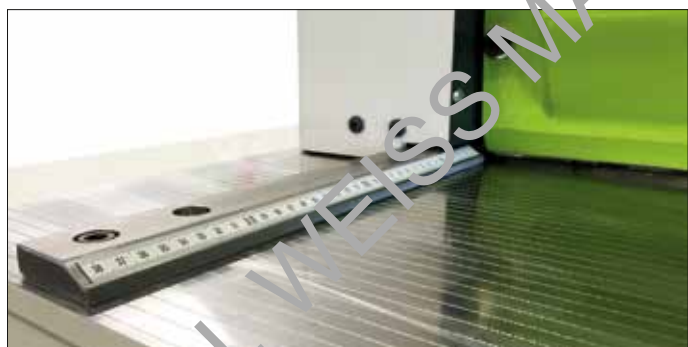

Flat table with measurement lines and standard left and right squaring arms.



Both RAPIDO and EVO provide easy access to all maintenance points and moving parts.

STANDARD

Pneumatic sheet support, flat table with measurement lines, LED cutting line light

Model	Cutting width	Capacity			Speed	Outer dimensions****	Motor	Weight
	mm (")	Steel* mm (ga)	Stainless steel** mm (ga)	Aluminium*** mm (")	Cuts/min.	Length x Width x Height mm (")	kW (hp)	kg (lbs) Approx.
RAPIDO 13	1350 (53)	3.50 (10)	2.00 (14)	5.00 (.196)	37	2060 x 1759 x 1534 (81x69x60)	3.0 (4)	1400 (3100)
RAPIDO 25	2550 (100)	2.50 (13)	1.60 (16)	3.70 (.145)	37	3191 x 1759 x 1534 (126x69x60)	3.0 (4)	1750 (3858)
RAPIDO 30	3100 (122)	2.50 (13)	1.60 (16)	3.70 (.145)	37	3741 x 1759 x 1534 (147x69x60)	3.0 (4)	1900 (4189)

Tensile strength *at 400 N/mm² - 58000 psi -**at 600 N/mm² - 87000 psi -***at 200 N/mm² - 29000 psi -**** with motorized back gauge 750 mm and safety guards



The CIDAN model **EVO** is the strongest shear in CIDAN’s shearing line. The **EVO**-series is a heavily built mechanical guillotine shear and is well equipped as standard. Blade gap adjustment, sheet support that follows the sheet down during the cutting operation and table rails with T-groove are some of the standard features. Furthermore **EVO** is also equipped with some “nice to have’s”, such as pneumatically controlled hold down beam as standard, to match the requirements of demanding customers.

- The blade gap adjustment makes it possible to achieve the best cutting result in all kind of sheet thicknesses. The blade gap is set quickly and correctly via two handles with scales.
- The rail arrangements on the table can be combined to meet the customer’s requirements – squaring arm and table extensions are available in different lengths with T-groove, tilting stops and scales.

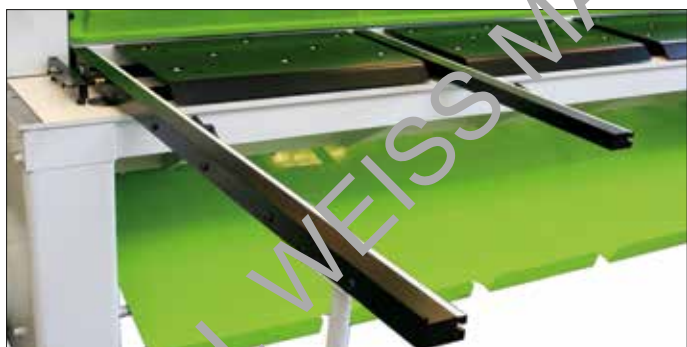

Flexible configuration possibilities with various pans, squaring and support arms.



Standard blade gap adjustment with scale, accurate cut from minimum to maximum thickness.

STANDARD

Pneumatic sheet support, blade gap adjustment, pneumatic hold down beam, LED cutting line light

Model	Cutting length mm (")	Capacity			Speed Cuts/min	Outer dimensions**** Length x Width x Height mm (")	Motor kW (hp)	Weight kg (lbs) Approx.
		Steel* mm (ga)	Stainless steel** mm (ga)	Aluminium*** mm (")				
EVO 30	3100 (122)	4.00 (9)	2.25 (14)	5.50 (.216)	28	3632 x 1600 x 1322 (143x63x52)	5.5 (7.5)	2850 (6283)
EVO 40	4100 (161)	2.50 (13)	1.60 (16)	3.70 (.145)	28	4592 x 1600 x 1322 (181x63x52)	5.5 (7.5)	3300 (7275)

Tensile strength *400 N/mm² - 58000 psi **600 N/mm² - 87000 psi ***200 N/mm² - 29000 psi -**** with motorized back gauge 750 mm and safety guards

SHEET SUPPORT SYSTEMS

When cutting thin materials the sheet must be supported to prevent it from hanging down during gauging against the back gauge rail. A sheet support system follows the upper beam to ensure support of the sheet throughout the cut. Additionally, **RAPIDO** and **EVO** shears can be supplied with different systems to deliver the cut-off sheets to the front or to the rear of the machine.

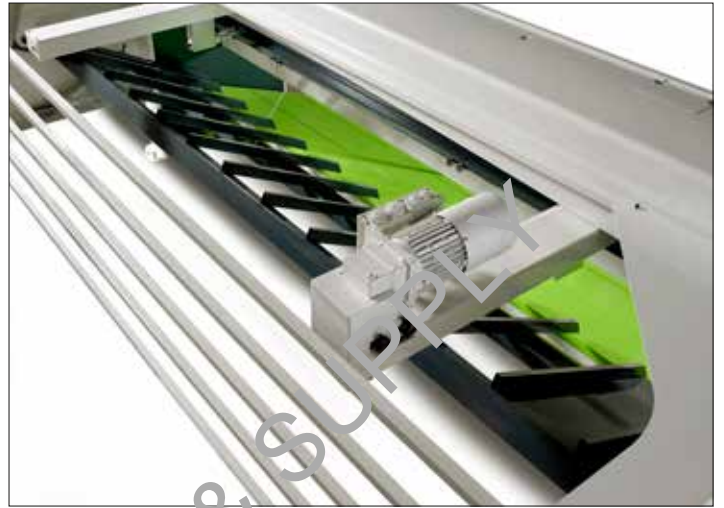

SHEET SUPPORT WITH RETURN PLATE (standard)

- Delivers the cut-off sheets to the front of the shear.
- The sheet support is pneumatically activated and has 3 selections: on, off or delayed, where the sheet support stays down until the cut sheet has been removed. This is an advantage for sheets less than 600 mm (23.6").
- This feature will save you time and effort because you do not have to go behind the shear after each cut.



MOVEABLE MATERIAL WAGON (option)

- Easily move cut material to another workstation
- Offered as an alternative to fixed return plate for return to sender and as option to delivery to the rear
- Extra wagon is available
- The handle can be removed and stored on the wagon
- Wagon can be picked up with a forklift
- Lockable wheels

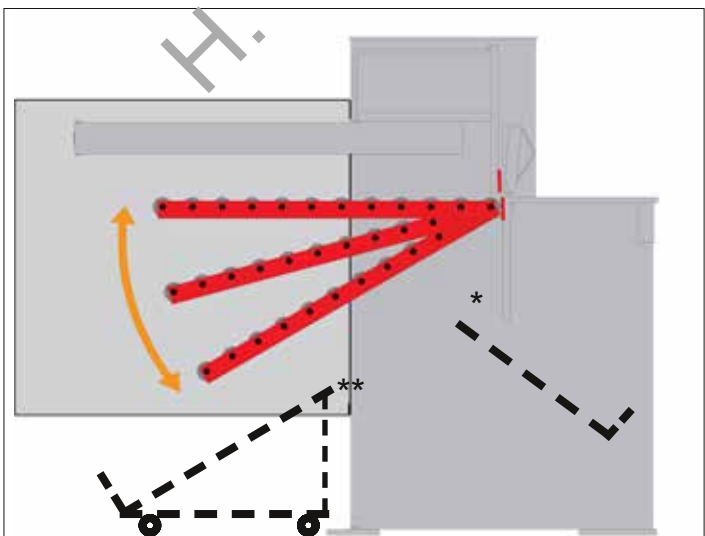

SHEET SUPPORT WITH DELIVERY TO THE REAR (option)

- Pneumatic sheet support with rolls, controlled by CutLink control system
- Delivers the cut-off sheets to the rear of the machine.
- Available for both **RAPIDO** and **EVO**
- Advantage for sheets larger than 600 mm (23.6")
- *Fixed return plate for sheets < 150 mm (5.9")
- **Moveable blank wagon on wheels for delivery to rear

MEASURING SYSTEMS



MANUAL BACK GAUGE

Operated from the front side of the machine.
Positioning via hand wheel and digital outread, 5-800 mm (.196-31.5").
Belt drive movement.



PROGRAMMABLE BACK GAUGE CutLink

The motorized back gauge with the rapid and accurate system CutLink has many interesting features for easier handling of sheets, such as selection of the sheet support position. Even the movement of the hold down beam can be controlled separately. Available in working depth 5-750 mm (.196-29.5") or 5-1000 mm (.196-39.3")

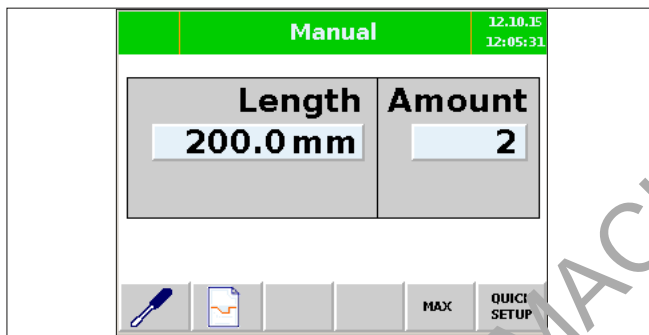

MANUAL MODE

Push on length, enter measure value for new position of back gauge. As soon as the dimension is acknowledged the back gauge will move to new position.
The amount counter can be set to count upwards or downwards. When changing the length, the counter resets.

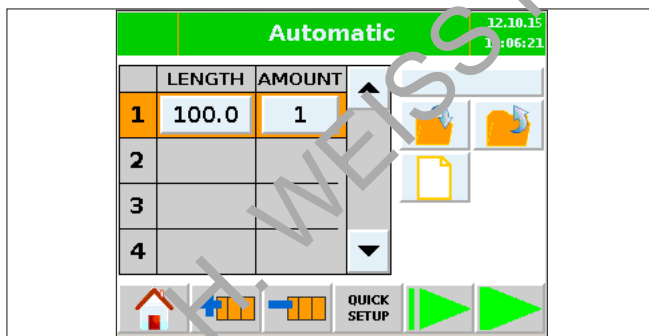

AUTOMATIC OPERATION

In automatic operation it is possible to program a number of different dimensions and amounts that will be executed in a sequence.

The program can contain 10 lines with different dimensions. To change values on length and dimension push on the text field and type in a new value.



BACK GAUGE

Ball screw spindle and belt drive ensures accurate and quiet positioning time after time.

SQUARING & SUPPORT ARMS

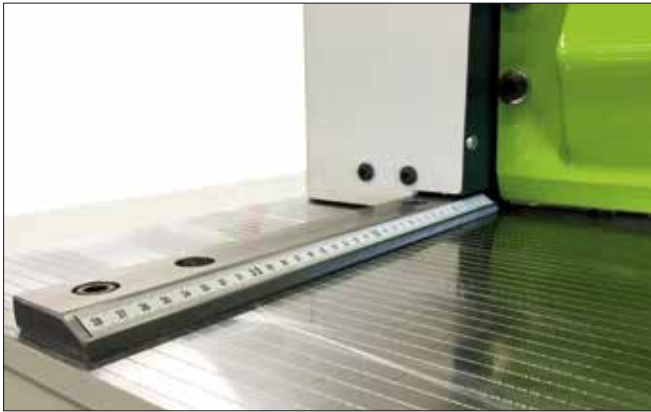

RAPIDO standard squaring arm mounted on both left and right side, length 380 mm (14.9").

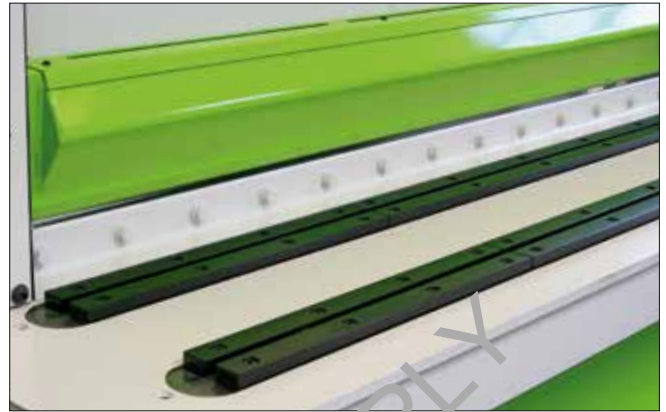

EVO table is configured from bottom up for every unique requirement. Two T-groove rails are standard.



Squaring arm with or without T-groove and tilting stop. Available from 440 mm (17.3") to 3000 mm (118") for **EVO**, and 1000 mm (39.3") or 2500 mm (98.4") for **RAPIDO**.

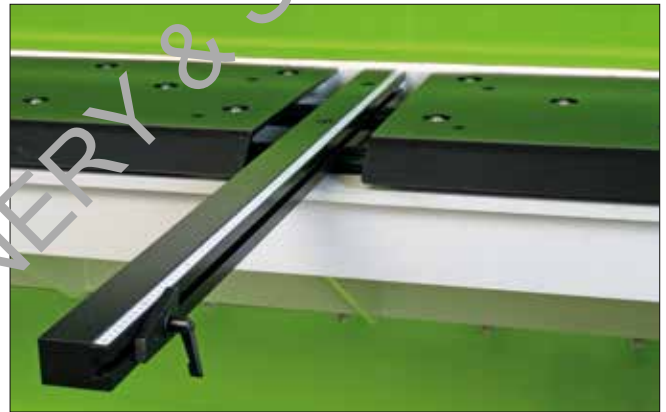

EVO table with support arm with T-groove and tilting stop and table pans 690 mm (27.1") with ball transfers. For **EVO** there are support arms from 416 mm (16.3") up to 3000 mm (118"), with or without tilting stop.



Retractable table extension available for **RAPIDO**, 800 mm (31").



Adjustable angle gauge with graduated scale.

SHEAR OVERVIEW

	RAPIDO	EVO
Back gauges		
Manual back gauge 5-800 mm (.196-31.5")	○	○
CNC-controlled back gauge 5-750 mm (.196-29.5") or 5-1000 mm (.196-39.3")	○	○
Sheet support options		
Fixed return plate (return to sender)	● ¹	● ¹
Moveable blank wagon	○	○
Pneumatic sheet support with rails of rolls (delivery to rear of machine)	○	○
Hold down beam		
Spring loaded	●	
Pneumatic	○	●
Safety		
Fixed side protection and fixed gate at the rear (only for return to sender)	○	○
Fixed side protection and a light beam at the rear	○	○
Front accessories		
Adjustable angle gauge with graduated scale	○	○
Retractable table extension bar	○	
Support arms 416-3000 mm (16.3-118")		○
Support arms with T-groove and tilting stop 650-3000 mm (25.6-118")		○
Squaring arm 1000 mm (39.3")	○	○
Squaring arms 440-3000 mm (17.3-118")		○
Squaring arms with T-groove and tilting stop 1000 mm (39.3") or 2500 mm (98.4")	○	○
Squaring arms with T-groove and tilting stop 440-3000 mm (17.3-118")		○
Table pans, 440 mm (17.3") or 690 mm (27.1")		○
Table pans with ball transfers, 440 mm (17.3") or 690 mm(27.1")		○
Other		
Forced cooling for cutting motor (for repetitive high volume cuts)	○	○
Conversion to 230V/3-phase	○	○

● standard, ○ option, ¹also possible as option to Pneumatic sheet support with rails of rolls (delivery to rear)

OUR COMPANIES



CIDAN Machinery Group markets the brands CIDAN, Göteneds and FORSTNER. Our machines are sold through dealers and agents in more than 30 countries.

We have produced sheet metal machines for over 110 years and today we offer a wide range of machines worldwide.

All our CIDAN and Göteneds machines are produced in our production facilities in Sweden. Machines for coil processing are produced in Austria by our company Forstner Maschinenbau, which has more than 60 years of experience in this field.

Our machines are based on our own developments and our own patents; we focus on flexible and simple-to-use solutions of the highest quality.



SWEDEN:
 Production, sales & service
 CIDAN Machinery Sweden AB
 P.O. Box 28
 SE-533 21 Götene
 Phone +46 (0) 511 245 20
 E-mail: info@cidanmachinery.com
 www.cidanmachinery.com

USA:
 Sales & service
 CIDAN Machinery Inc.
 611 Highway 74 South, Suite 700
 Peachtree City, GA 30269
 Phone +1 770-692-7230
 E-mail: info@cidanmachinery.com
 www.cidanmachinery-americas.com

CHINA:
 Sales & service
 CIDAN Machinery Shanghai Co, Ltd.
 No.1155 Yuanda Road Anting Town
 Jiading District, Shanghai, 201805
 Phone +86(0) 21-39 50 11 08
 E-mail: info@cidanmachinery.cn
 www.cidanmachinery.cn

AUSTRIA:
 Production, sales & service
 Forstner Maschinenbau GmbH
 Studa 9
 6800 Feldkirch
 Phone +43 5522 74 309
 E-mail: office@forstnercoil.at
 www.forstnercoil.at

DENMARK:
 Sales & service | Phone +46 (0) 511 245 20 | www.cidanmachinery.dk

MALAYSIA:
 Sales | Phone +60 162 169 102 | E-mail: info@cidanmachinery.com

Note 1: Machines pictured in the catalogue may be equipped with options
 Note 2: Please refer to our website for the latest news and valid product information

